



A Provider's Guide to
Hereditary Cancer

The Basics of Cancer Genetics



Sporadic Cancer

- All cancer is caused by multiple **mutations** in genes that play important roles in regulating cell growth. An accumulation of these mutations over many years can allow cells to divide uncontrollably and form tumors.
- The **majority** of cancer cases are sporadic, or caused by acquired gene mutations that occur due to random chance during cell division or by carcinogens in the environment (e.g., tobacco smoke, UV rays, and certain chemical exposures).

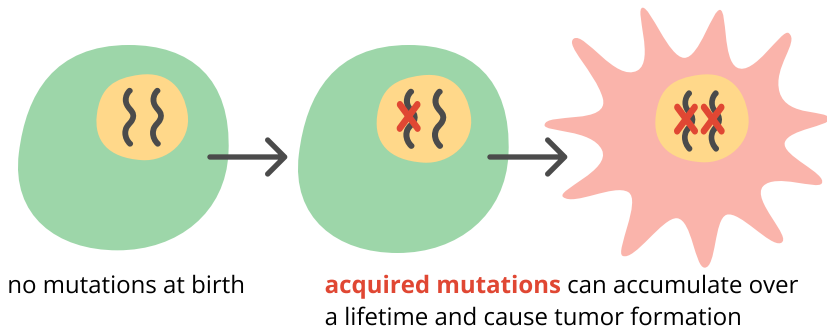

- These acquired gene mutations **cannot be passed on to children**. A history of sporadic cancer therefore does not incur a greater risk of cancer to other family members. However, any shared carcinogenic environmental exposures should be avoided.
- **Somatic tumor testing** can reveal acquired genetic mutations and may guide cancer treatment recommendations.

If a hereditary cancer syndrome is suspected, genetic testing can inform an entire family's screening practices and **save lives**.

Hereditary Cancer

- **Up to 10%** of cancer cases are caused by an inherited cancer syndrome, or an inherited mutation in a cancer susceptibility gene.
- These inherited mutations increase the risk of developing specific cancers over a lifetime and **can be passed on to children**.
- **Germline genetic testing** can reveal these inherited mutations and explain a personal or family history of cancer. Identification of a hereditary cancer syndrome can also guide screening and risk-reducing recommendations.

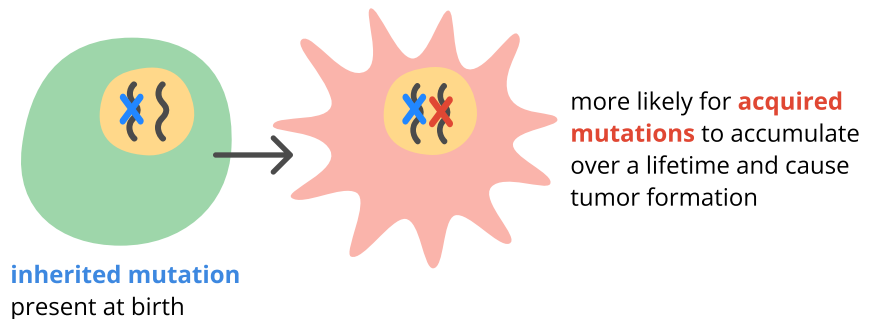

- Cancer can also appear to “run in a family” without being hereditary, known as **familial** cancer. Familial cancer may be caused by shared environmental exposures, random chance, or a combination of many small genetic and environmental risk factors.

Identifying a Hereditary Cancer Syndrome

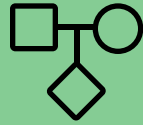

Personal and Family History

- Certain patterns of personal and family histories of cancer can suggest a hereditary cancer syndrome. **Genetic counselors** are trained to analyze a family tree for signs of specific hereditary cancer syndromes.
- Most hereditary cancer syndromes are inherited in an **autosomal dominant pattern**, meaning that first-degree family members (parents, siblings, and children) each have a 50% chance of having the syndrome.

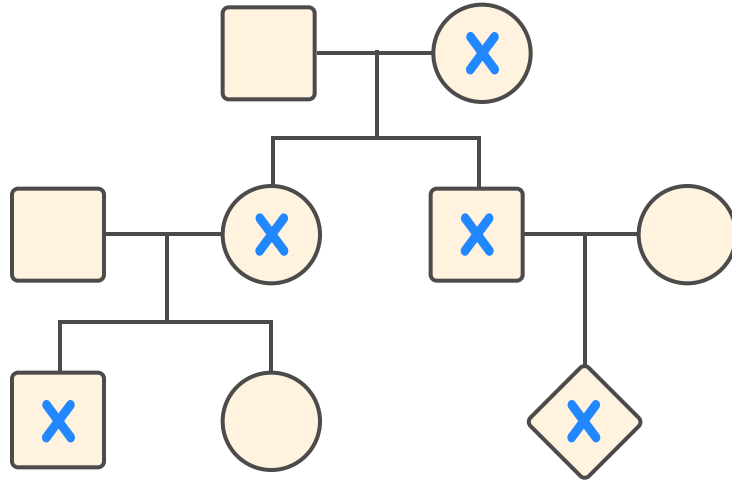

X related types of cancer

Signs of Hereditary Cancer Syndromes

Patients should be referred to a genetic counselor if they have a personal or family history of any of the following:

- **≤50** Any cancer with onset at **age 50 or younger**
- **!** **Rare** types of cancer (such as ovarian, male breast, or pancreatic cancer)
- **---** **Triple-negative** breast cancer (ER-, PR-, HER2-)
- **2+** **Multiple relatives** with the same or related types of cancer (such as breast and ovarian, or colon and endometrial cancer)

Genetic Testing

- If a hereditary cancer syndrome is suspected, patients should meet with a **genetic counselor** to discuss their personal and family history in more detail. The genetic counselor will then determine the most appropriate **germline genetic testing** option.
- If genetic testing reveals an inherited cancer risk, the specific gene mutation can guide **early cancer screening**, more effective treatment if cancer develops, and, in some cases, preventative action that reduces the risk of developing cancer.
- In addition, family members can be tested for the mutation to determine whether they should also follow these recommendations.

Common Hereditary Cancer Syndromes



BRCA1/2-Associated Cancer Susceptibility

- Inherited mutations in the *BRCA1* and *BRCA2* genes are the most common cause of hereditary breast and ovarian cancer.
- These mutations increase the lifetime risk of **breast** (female and male), **ovarian**, **prostate**, **pancreatic**, and **melanoma** cancers.

Cancer	General Population Lifetime Risk	BRCA1 Lifetime Risk	BRCA2 Lifetime Risk
Breast	13%	>60%	>60%
Ovarian	1%	39-58%	13-29%
Prostate	13%	7-26%	19-61%
Pancreatic	2%	<5%	5-10%
Male Breast	<1%	<1-1%	2-7%



Red flags: breast cancer at age 50 or younger, triple negative breast cancer, male breast cancer, ovarian cancer, pancreatic cancer, metastatic or high-grade prostate cancer, Ashkenazi Jewish ancestry



Implications: earlier mammograms/breast MRIs, risk-reducing surgeries, risk-reducing medication, PARP-inhibitor cancer treatment



Guidelines: NCCN "Genetic/Familial High-Risk Assessment: Breast, Ovarian, and Pancreatic"

Lynch Syndrome

- LS is caused by inherited mutations in the *MLH1*, *MSH2*, *MSH6*, *PMS2*, and *EPCAM* genes. These mutations increase the lifetime risk of **colorectal**, **endometrial**, **ovarian**, **prostate**, and **other** cancers (bladder, urinary tract, gastric tract, small bowel, pancreatic, and brain cancer).
- Exact cancer risks and screening recommendations depend on which gene is affected, for example:

Cancer	General Population Lifetime Risk	MLH1 Risk by 80y	MHS2 Risk by 80y
Colorectal	4%	46-61%	33-52%
Endometrial	3%	34-54%	21-57%
Ovarian	1%	4-20%	8-38%
Prostate	13%	4-14%	4-24%
Other	---	Up to 28%	Up to 11%



Red flags: colorectal or endometrial cancer at age 50 or younger, multiple LS-related cancers in a person or family, microsatellite instability (MSI) or lost of mismatch repair (MMR) protein expression on tumor testing



Implications: earlier colonoscopies, upper endoscopies, family-specific screening, risk-reducing surgeries



Guidelines: NCCN "Genetic/Familial High-Risk Assessment: Colorectal"

Hereditary Cancer Workflow: Red Flag Checklist



No to ALL

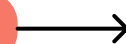

Counsel on sporadic cancer (p.9)

Yes to ANY



Counsel on hereditary cancer and refer to genetic counselor (p.10)

Colon or Endometrial Cancer

Personal history:

- Diagnosed <50 yrs?
- MSI or loss of MMR protein expression on tumor testing?
- Synchronous or metachronous LS-related cancer**?
- ≥1 first or second-degree relative with LS-related cancer** diagnosed <50 yrs?
- ≥2 first or second-degree relatives with LS-related cancer**?
- PREMM5 predictive model score of ≥2.5%?

Family history only:

- ≥1 first-degree relative with colorectal or endometrial cancer diagnosed <50 yrs?
- ≥2 first or second-degree relatives with LS-related cancer**, 1 diagnosed <50 yrs?
- ≥3 first or second-degree relatives with LS-related cancer**?
- PREMM5 predictive model score of ≥5%?

Breast Cancer

Personal history:

- Diagnosed ≤50 yrs?
- Triple negative?
- Male?
- Ashkenazi Jewish ancestry?
- Multiple primary (synchronous or metachronous)?
- Lobular with personal/family history of diffuse gastric cancer?
- ≥1 close relative* with breast diagnosed ≤50 yrs, male breast, ovarian, pancreatic, or metastatic/high-risk prostate cancer?
- ≥2 close relatives* with breast or prostate cancer?
- ≥3 total diagnoses of breast cancer in patient and/or close relatives*?

Family history only:

- First or second-degree relative with above personal history?
- HBOC predictive model probability of >5%?

*Close relatives: first, second, or third-degree relatives on same side of family

Prostate Cancer

Personal history:

- Metastatic?
- High or very high-risk based on NCCN Guidelines for Prostate Cancer?
- Ashkenazi Jewish ancestry?
- ≥1 close relative* with breast diagnosed ≤50 yrs, triple negative breast, male breast, ovarian, pancreatic, or metastatic/high-risk prostate cancer?
- ≥2 close relatives* with breast or prostate cancer?

Family history only:

- First-degree relative with above personal history?

Colon Polyps

Personal or family history:

- ≥10 adenomatous polyps?
- ≥2 hamartomatous polyps?
- ≥5 serrated polyps?

**Lynch syndrome (LS)-related cancers: colorectal, endometrial, ovarian, prostate, small bowel, gastric, pancreatic, bladder, renal pelvis and/or ureter, biliary tract, brain, skin (sebaceous adenomas, sebaceous carcinomas, and keratoacanthomas)

Hereditary Cancer Workflow: Next Steps



No to ALL

Counsel the patient on sporadic cancer

Key points to communicate to the patient:

- Most often, cancer occurs “sporadically” due to **random chance** or exposure to **carcinogens**. This is most consistent with your personal/family history.
- When cancer occurs sporadically, a personal/family history **does not incur greater risk to other family members**. However, any shared carcinogenic environmental exposures should be avoided.
- Since we aren't suspicious of an inherited cancer risk, we **do not recommend further genetic evaluation** at this time. However, it's important to keep us updated on any changes to your family history.

Questions?

Talk to a certified genetic counselor by calling:

Phone: 1-800-364-1641

Yes to ANY

Counsel the patient on hereditary cancer

Key points to communicate to the patient:

- **5-10%** of cancer cases are hereditary, or caused by an inherited genetic difference that increases the lifetime risk of developing specific types of cancer.
- When hereditary, **other family members are also at risk** of having a predisposition to cancer.
- **Genetic counseling and testing** can help identify an inherited cancer risk. Knowing about this risk in advance can inform cancer screening and preventative care.

Refer the patient to a GSF genetic counselor

- Fax the relevant medical records and insurance information to Genetic Support Foundation at:

Fax: 844-813-3892

- We will then contact the patient to schedule an appointment. With the patient, we will discuss their personal/family history in more detail and offer the most appropriate genetic testing.
- Once the results are back, we will walk the patient through the information and send your office a results summary and recommendations for their care.